



Installation and Configuration

TABLE OF CONTENTS

1. OVERVIEW	3
1.1 Terminology	3
2. XST8803 Control Interface Installation	5
3. TST8804 Control Unit Installation	6
4. TST8805 Intelligent Controller DC Power Unit Installation	7
5. TST8801 Intelligent Controller Input Box Installation.....	7
5.1.1 Technical specifications	7
5.1.2 TST8801 Connections.....	8
5.1.3 Setting the module address	8
5.1.4 Connecting the data cable	9
5.1.5 Connecting a light switch or electric feed	9
6. IC CONFIGURATOR SOFTWARE INSTALLATION	9
7. CONFIGURATION	10
7.1 Configuring a Switch Setup	11
7.2 File Menu.....	12
7.3 Action Menu	12
8. LOGIC GROUP	13
8.1 Forming a Logic Group	13
APPENDIX 1: SETUP EXAMPLE	14
APPENDIX 2: Wiring Diagrams	17

1. OVERVIEW

Teknoware Intelligent Controller (IC) makes it possible to integrate Teknoware's addressable emergency luminaires to a building's general lighting system and to control the luminaires with any standard lighting control devices, such as light switches.

One or more luminaires may be assigned to one switch, and more than one switch can be used for controlling a single luminaire or a group of luminaires. Any addressable emergency luminaire can be switched on through any freely selectable voltage input (8 pcs) of a TST8801 control unit. Each voltage input has its own galvanically separated L and N connection.

The Intelligent Controller also makes it possible to monitor the voltage on a certain location of the electric feed, and use the voltage or lack of voltage as a virtual switch. For example, the emergency luminaires specified in the IC can be configured to turn on automatically to provide sufficient illumination for an area if a fuse is blown.

With the possibilities provided by the Intelligent Controller, the emergency lighting can be seamlessly integrated to the general lighting of the building.

The Teknoware Intelligent Control system consists of:

- TST8801 IC Input Box unit / units (up to 31 pcs)
- TST6x5x Intelligent Controller interface (for CBU), including the following components:
 - XST8803 Control Interface (installed inside the TST6x5x CBU)
 - TST8804 Control Unit
 - TST8805 Power Supply
 - TST8851 IC Configurator software

The configuration of the system and the luminaires is done with the *IC Configurator* software through a USB interface in the TST8804 Control Unit during the implementation of the system. The data between the Input Boxes and the Control Unit in the CBU travels through a 2-core data cable. The maximum length of the cable is 1,500 m.

The luminaire control package can be used with the Teknoware TKT6x Central Battery Units and K-type addressable emergency luminaires. Each TST8801 has its individual address which is set with a DIP switch.

1.1 Terminology

- **CBU** – Central Battery Unit
- **Board** – The Circuit Board inside the CBU. Each CBU may contain from 1 to 7 boards.
- **Circuit** – The power part on the board. Each board can contain 2, 4 or 8 circuits. Each circuit consist of HI and LO parts, and may contain up to 32 luminaires.
- **Input Box** – TST8801 input module with 8 input channels. The whole system may contain up to 31 Input Boxes.
- **Channel** – each Input Box contains 8 channels, which can be set to monitor standard lighting controls (such as light switches, motion detectors etc.). A channel can also be set to monitor

an alarm device or simply a voltage on a certain point (for example the voltage after a fuse box). A channel can be non-inverted (triggers according to the feed, for example turns the luminaires ON when a switch is turned ON) or inverted (triggers when feed is not detected, for example turns the luminaires ON when voltage is not detected after a fuse box).

- **Logic Switches** – virtual switches that can be set to monitor voltage or lack of voltage on a specific location in the electric feed.
- **Logic Groups** – groups of channels defined in the IC Configurator software. Triggering a single channel within this group will affect all the luminaires within this group.

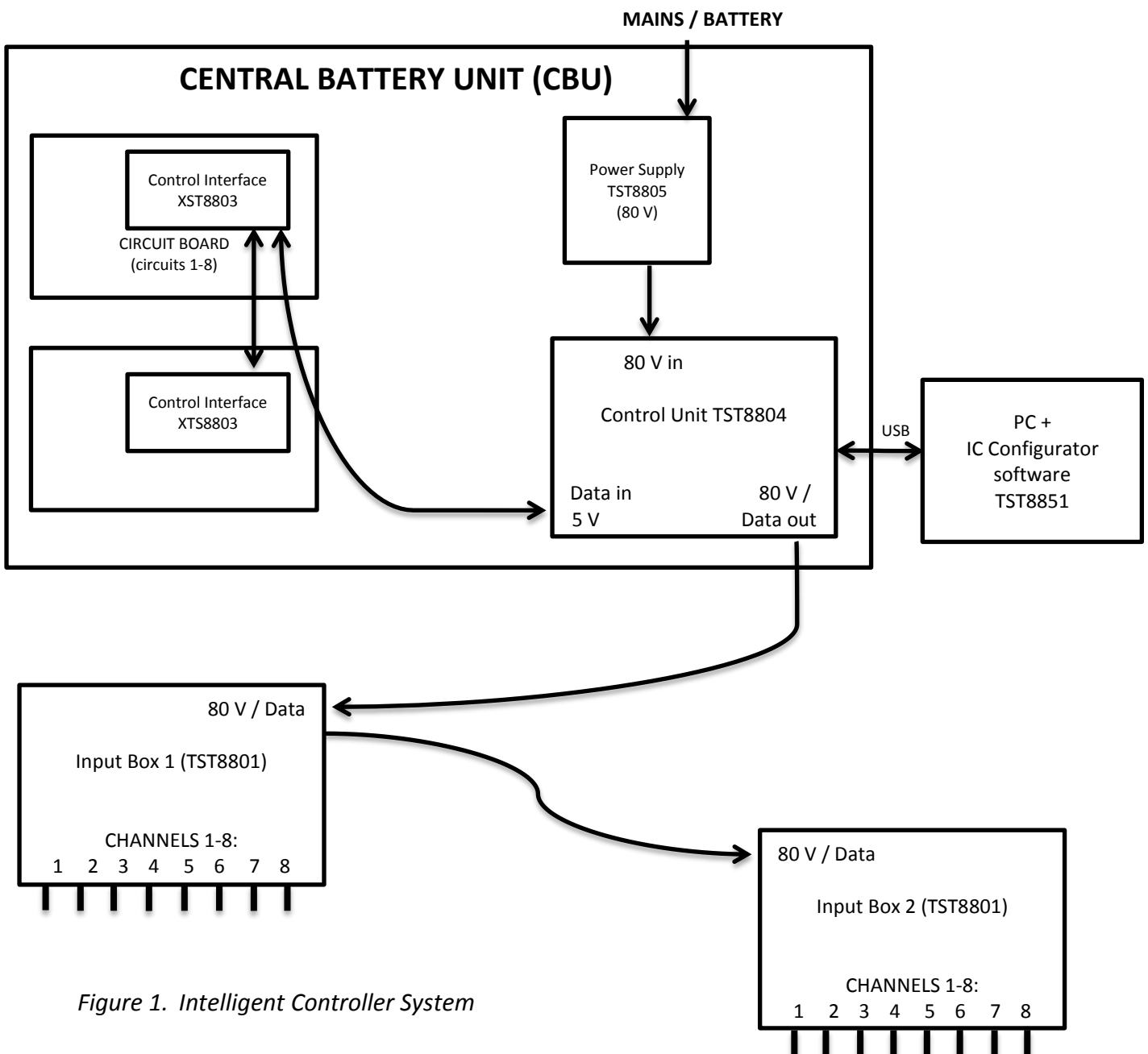

Figure 1. Intelligent Controller System

2. XST8803 CONTROL INTERFACE INSTALLATION

NOTE!

Physical installation of this system is allowed only to a qualified electrician who has the required permissions and qualifications. National regulations for electric installations and building codes must be observed.

NOTE!

Only original spare parts may be used for this product. Any modifications to this product without a written consent from the manufacturer are prohibited. This product may only be used for purposes specified by the manufacturer.

WARNING!

There is dangerous voltage level in the output circuits and inside the Central Battery Unit. Device must be made de-energized before installing this product. See the separate Installation and Maintenance Guide for the CBU before installing this product.

If not pre-installed, install the XST8803 Control Interface(s) to the circuit board(s) of the CBU by pressing the Interface in its place carefully, as illustrated in *Figure 2*. Make sure that all the connectors fit in their corresponding places. See *Appendix 2 Wiring Diagrams* for detailed information.

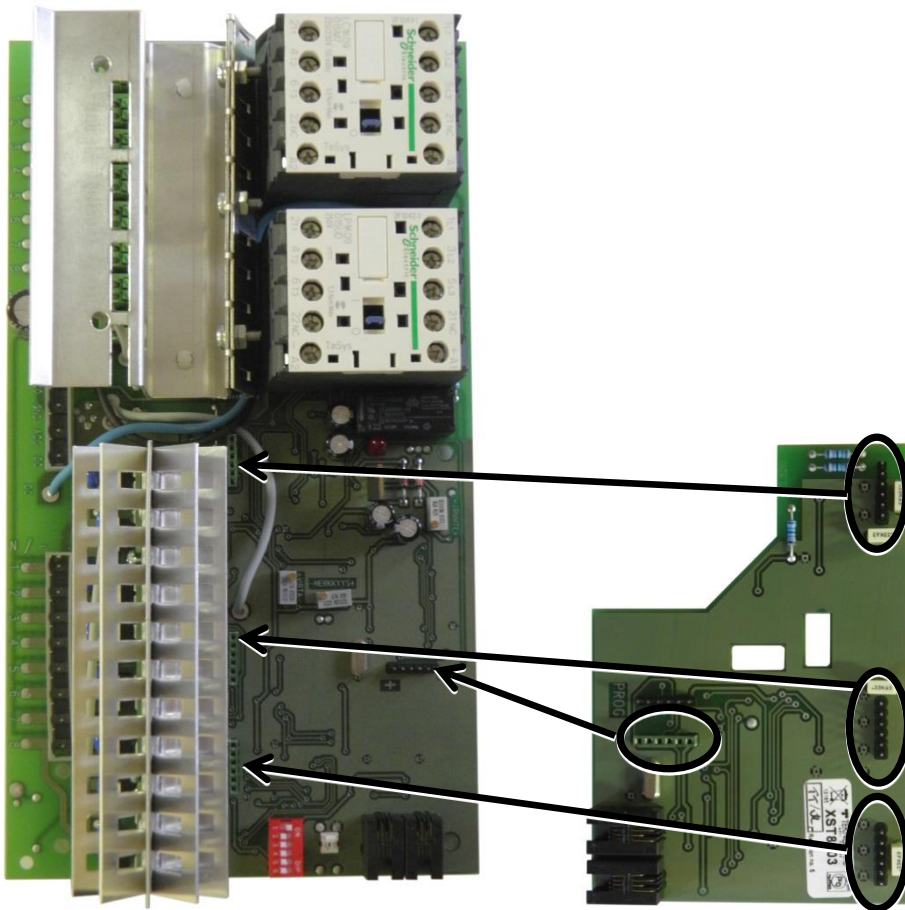

Figure 2. XST8803 Control Interface Installation

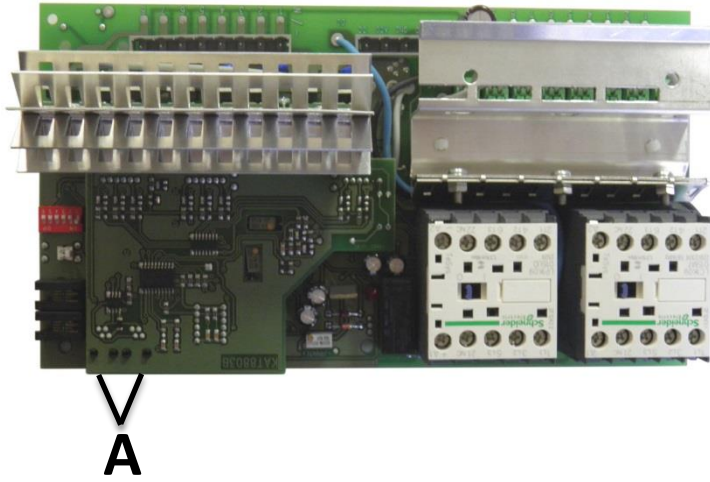

Figure 3. XST8803 Control Interface

A: RS-485 data cable connection for additional XST8803 Interfaces and to TST8804 Control Interface (see **D** in Figure 4)

After installing the XST8803 Control Interfaces to the circuit boards, connect them with a RS-485 data cable. See *Appendix 2 Wiring Diagrams* for detailed information.

3. TST8804 CONTROL UNIT INSTALLATION

If not pre-installed, install the TST8804 Control Unit in the CBU by attaching it to a DIN rail in a convenient location. The connections of the module are as follows:



Figure 4. TST8804 Intelligent Luminaire Controller

- A:** Power in (80 V) from TST8805
- B:** Data and power out, a connection to the first TST8801 unit
- C:** Connection for the PC with the IC Configurator software (via a USB cable)
- D:** Connection for the RS-485 data cable from the XST8803 Control Interface (inside the CBU)

After installing the TST8804 Control Unit to the CBU, connect it to the XST8803 Control Interfaces with a RS-485 data cable. See *Appendix 2 Wiring Diagrams* for detailed information.

4. TST8805 INTELLIGENT CONTROLLER DC POWER UNIT INSTALLATION

Install the TST8805 DC Power Unit in the CBU with screws. Connect the unit according to the information provided in *Appendix 2 Wiring Diagrams*.



Figure 5. TST8805 Intelligent Controller DC Power Unit connections

- A:** Uin connection from the CBU
- B:** 80 VDC out connection to TST8804

5. TST8801 INTELLIGENT CONTROLLER INPUT BOX INSTALLATION

TST8801 module should be installed inside an electric cabinet or to a similar location. The module is DIN-rail compatible.

NOTE!

The connectors of this device have a potentially dangerous electric current. Install the module only to a safe location, and observe local laws and regulations.

5.1.1 Technical specifications

Input voltage	Nominal: 80 VDC Min-Max: 60-120 VDC
Type of insulation between the inputs and the data in/out:	Reinforced
Max. distance from the CBU	1500 m
Mounting:	DIN-rail
Ambient temperature range:	-25°C...+50°C
Directives applied:	LVD- and EMC directives

5.1.2 TST8801 connections

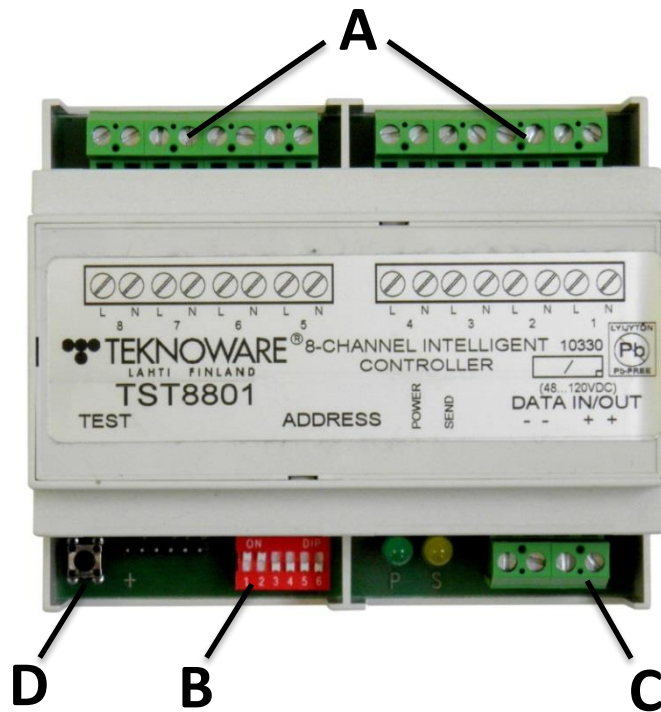



Figure 6. TST8801 Intelligent Controller Input Box connections

- A:** Monitoring input channels (8 potential free isolated L/N inputs)
- B:** DIP switch for setting an address for the module (1-31)
- C:** Data IN-OUT connection (Data and power supply in the same 2 conductor cable)
- D:** Test button (sends the current state to the CBU)

5.1.3 Setting the module address

The address is set by using the DIP switch. Note that DIP 6 is not in use. Setting the address to 0 disables the module. The address is set according to the following chart (the mathematical values of the DIP switches are displayed in the left column):

		Address chart																
DIP 1 = 1 DIP 2 = 2 DIP 3 = 4 DIP 4 = 8 DIP 5 = 16 DIP 6 = 0	DIP																	
		=	0	1	2	3	4	5	6	7	8	9	10	11	12	13	14	15
	DIP																	
		=	16	17	18	19	20	21	22	23	24	25	26	27	28	29	30	31
			= DIP OFF															
			= DIP ON															

The address can be chosen freely according to the installation plan. However, care must be taken that each module in the system has a different address.

5.1.4 Connecting the data cable

Connect the 2-core data cable from the TST8804 Intelligent Luminaire Controller to the Data IN/OUT connectors of the first TST8801 module according to the instructions on the label of the module. Then, connect the next TST8801 module to the first module in a similar way. See *Appendix 2 Wiring Diagrams* for detailed information.

NOTE!

Data and power supply are in the same cable.

5.1.5 Connecting a light switch or electric feed

Connect the Channel N/L connections of the TST8801 unit to electric feeds according to the connection plan. A channel may be connected to any 230 V electric feed (for example to an electric feed going to a luminaire after a light switch, or to a fuse box). The TST8801 module monitors the change of current, i.e. whether or not a current exists, and communicates changes in said state with the TST8804.

6. IC CONFIGURATOR SOFTWARE INSTALLATION

Requirements

The IC Configurator software is compatible with the Windows XP and Windows 7 (32/64) operating systems.

To install the IC Configurator software:

1. Log in as Administrator, or make sure you have the administrator password available.
2. Disable all rest modes and power saving modes before installing the software. Connect the IC Configurator USB drive to a USB port and open the root folder.
3. Run the installation wizard (*ILC_config_1.2.exe*). The installation wizard will guide you through the installation process.

The installation packet includes a Java application software.

7. CONFIGURATION

After installing the IC configurator software to a PC and configuring the CBU, connect the USB cable between the PC and the USB socket on the TST8804 Control Unit (**C** in *Figure 4*). A yellow indicator LED will be lit on the TST8804 when the connection is established.

Run the IC Configurator software from a shortcut or from the executable file in the installation folder. Board 1 is opened as a default.

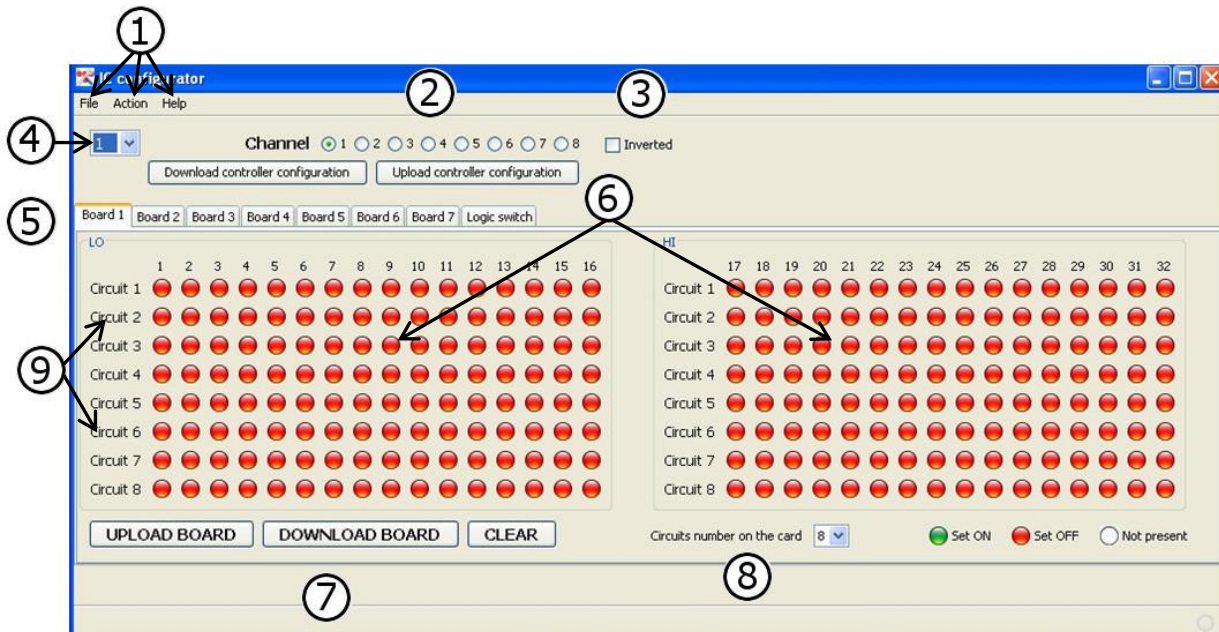

Figure 7. Main screen

1. File, Action and Help menus
2. Channel selection, Download / Upload Controller Configuration buttons.
3. Inverted option
4. Input Box selection (see chapter 5.1.3 *Setting the module address* for details)
5. Board Selection tabs and Logic Switch tab
6. Luminaires present in the currently selected board
7. Upload Board, Download Board and Clear buttons
8. Number of circuits on the current board
9. Circuit labels

If a switch setup is already configured, the configuration is displayed. If luminaires are not yet configured to the software, click the Download Board button to download information about the

connected luminaires for the current board or the click the Download Controller Configuration button to download the information from the currently selected Input Box. You can also select the Action -> Read Configuration option to read the configuration of the entire system.

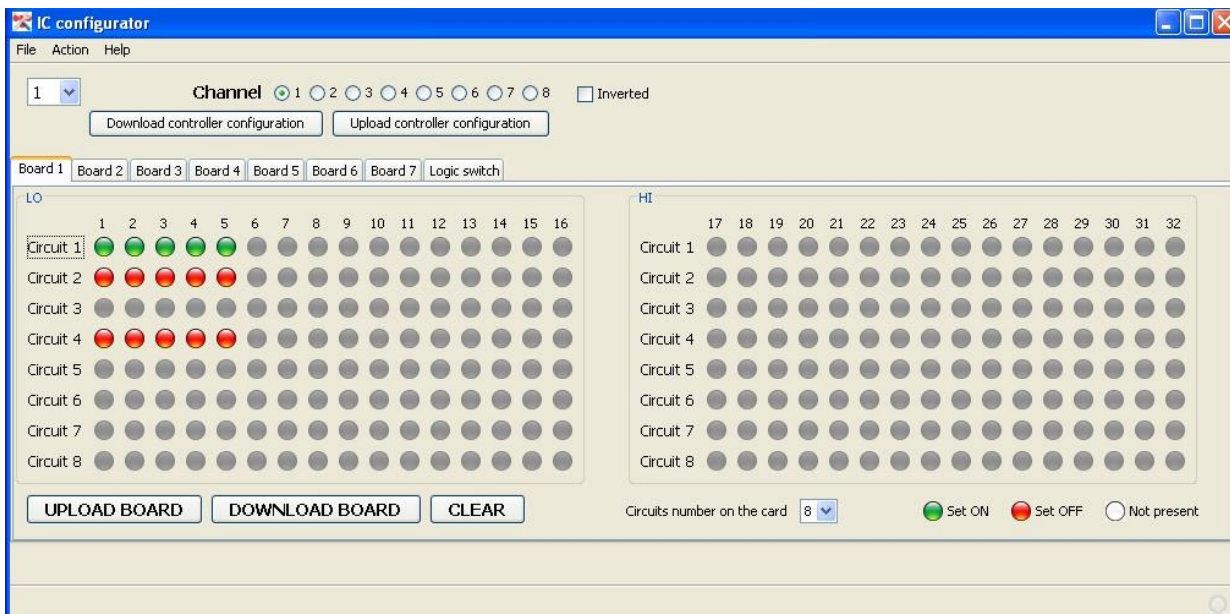

Figure 8. Configuration received

7.1 Configuring a Switch Setup

1. Select the correct number of circuits on the board (2, 4 or 8) from the drop down list.
2. Choose the Input Box number from the drop down menu in the up-left corner.
3. Select the channel to which the switch is physically connected.
4. Configure the luminaires to be controlled by the switch by clicking on the corresponding luminaire symbols (nr 6 in Figure 4). A green symbol indicates that the luminaire will be affected by the switch in question. Note that luminaires from any circuit and from any board can be assigned to any switch.
5. A luminaire can be controlled by more than one switch. In this case the luminaire will be switched ON / OFF by any of the defined switches.
6. An entire circuit can be selected by clicking the corresponding label.
7. If you need to clear all selections, click the Clear button.
8. When all the luminaires are selected for the switch in question, click the Upload Board button to store the setup of a single board or click the Upload Controller Configuration button to store the setup of a single Input Box.
9. You can also select the Action -> Write Configuration option to write the configuration of the entire system.

7.2 File Menu

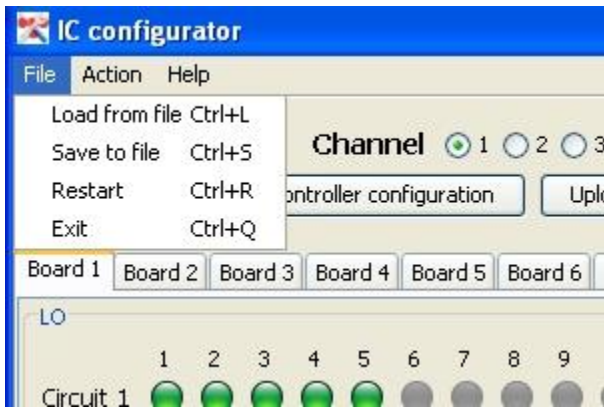

Figure 9. File menu

1. Save to file – Saves the configuration data for all Input Boxes to a file. To save the entire configuration, for example for a backup or for transferring a setup to an identical building, read the configuration by using the Action → Read Configuration option before saving the configuration to a file.
2. Load from file – Loads the configuration data for all Input Boxes from a file.
3. Restart – Clears all configuration data and restarts the software
4. Exit – Closes the software

7.3 Action Menu

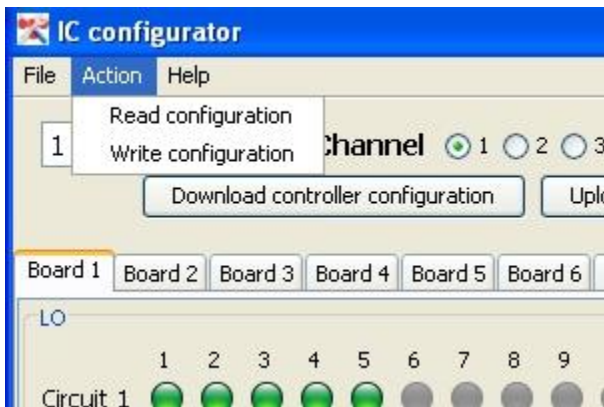

Figure 10. Action menu

1. Read configuration – reads all the configuration data for all the Input Boxes. This may last for a few minutes depending on the system configuration. This option is used for example before saving the configuration to a file.
2. Write configuration – stores all the configuration data for all the Input Boxes. Writing the configuration lasts approx. 5 times longer than reading the configuration. This option is used for restoring a backup configuration from a PC, after loading the configuration from a file.

8. LOGIC GROUP

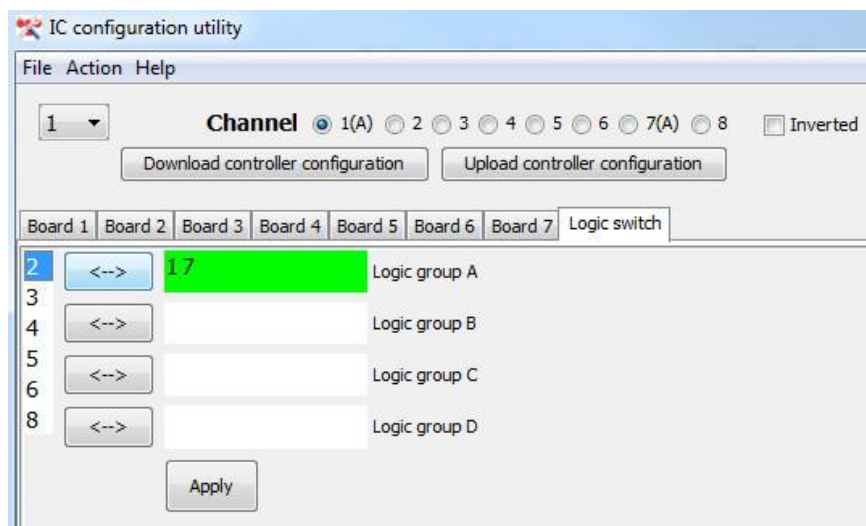

Figure 11. Logic Switch tab

Logic Groups are groups or individual channels from a single Input Box that control a specific group of luminaires. If any of the channels in the group is triggered, all the luminaires set under this group are affected. A Logic Group can also be used as inverted. If a Logic Group is triggered, the lit emergency luminaires cannot be turned OFF via other switches until the original problem is solved. For example if a fuse is blown, the emergency luminaires will stay lit until the power is restored. This is why it is sometimes useful to set a single channel as a Logic Group.

Each Input Box can contain up to 4 Logic Groups (A-D).

8.1 Forming a Logic Group

1. Go to the Logic Switch tab.
2. Select the correct Input Box just like when configuring a normal switch.
3. If you want to make an inverted Logic Group, check the Inverted box.
4. Move the channels you want to combine to a Logic Group by selecting a channel from the left side of the window and by clicking the <--> button beside the correct group (A-D). In the figure above, channels 1 and 7 have been added to Logic Group A.
5. Each group can contain 1-8 channels.
6. Click the Apply button when the groups are complete.
7. While a channel from this group is selected from the Channel selection, browse the Board tabs and select all the luminaires you want to assign under this group just like when configuring a normal switch. The luminaires you select will be added to each channel within this group.
8. Click the Upload Controller Configuration button from the Logic switch tab to save the configuration.

The Logic Group is now complete. Whenever any of the channels within said group is triggered, all the luminaires under said group will be lit.

APPENDIX 1: SETUP EXAMPLE

This example of an IC system consists of three rooms and a corridor including 12 luminaires (7 normal lights and 5 emergency luminaires). A light switch (SW1) is controlling the three lights in the corridor and three separate light switches (SW2, 3, 4) are controlling the lights in each of the rooms. Two Input Boxes are in use (total of 16 channels). The IC monitors the voltage going to the lighting after the fuse box. The IC also monitors a customer specified alarm device. If this alarm device is triggered, all emergency luminaires are lit.

Please note, that the example is simplified in order to explain the concept. Each channel can control any or all luminaires in the system.

- The **Control Unit** (TST8804) communicates with the Input Boxes and the CBU (via. Control Interface).
- The **Input Box(es)** (TST8801) monitor normal light switches or voltage.
- If a **monitored light switch (SW)** is turned, the Input Box monitoring said switch sends a status update to the CBU, which turns the emergency luminaire(s) under said switch ON or OFF (depending on what state the luminaire was).
- In other words, even though the users experience is that turning the light switch turns the lights (both normal and emergency luminaires) ON or OFF, **the emergency luminaires are controlled by the IC system, not directly by the physical switch.**
- Luminaires 3 and 4 in the example figure are both behind the same switch, and are both lit or turned off if SW4 is turned.
- Monitoring the switches does not affect the normal functionality of the switches, i.e. normal lights function as usual.
- **Inverted Logic Group A** monitors the voltage being fed to the lights after the fuse box through Channel 1, and an alarm device through Channel 7. This group affects all the emergency luminaires in the area. In case of a power failure, or if the feed from the alarm is lost, all emergency luminaires are lit.
- In case of an emergency, the emergency luminaires are switched on. All switches, whether logical or physical, are ignored.

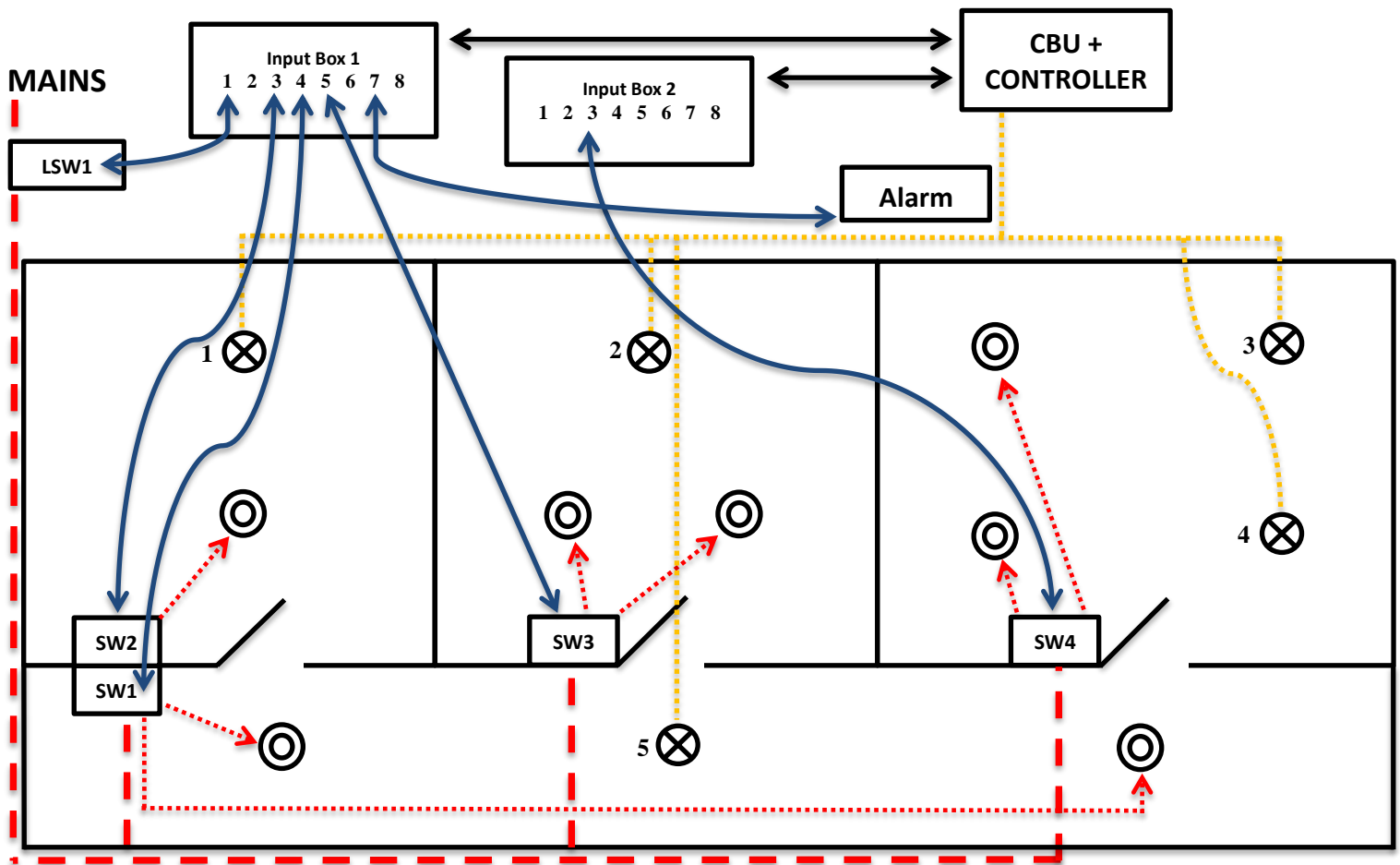

	Emergency luminaire		Current from switches to normal luminaires
	Normal luminaire		Communication between switches and Input Box
	Current from CBU to emergency luminaires		Current from mains to switches

Luminaire (on the map)	Input Box / Channel	Address
1	1 / 3	Board 1, Circuit 2, Luminaire 4
2	1 / 5	Board 1, Circuit 2, Luminaire 6
3	2 / 3	Board 1, Circuit 5, Luminaire 1
4	2 / 3	Board 1, Circuit 1, Luminaire 1
5	1 / 4	Board 1, Circuit 1, Luminaire 2

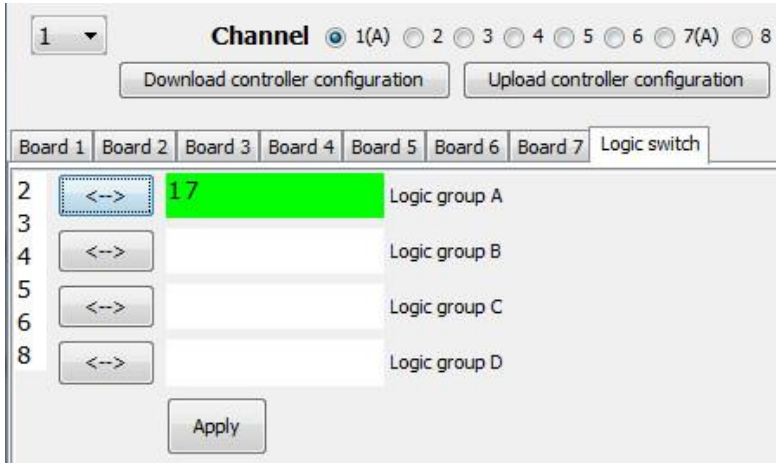

Logic group 1A: Input Box 1, Channels 1 and 7 (=LSW1 and Alarm)

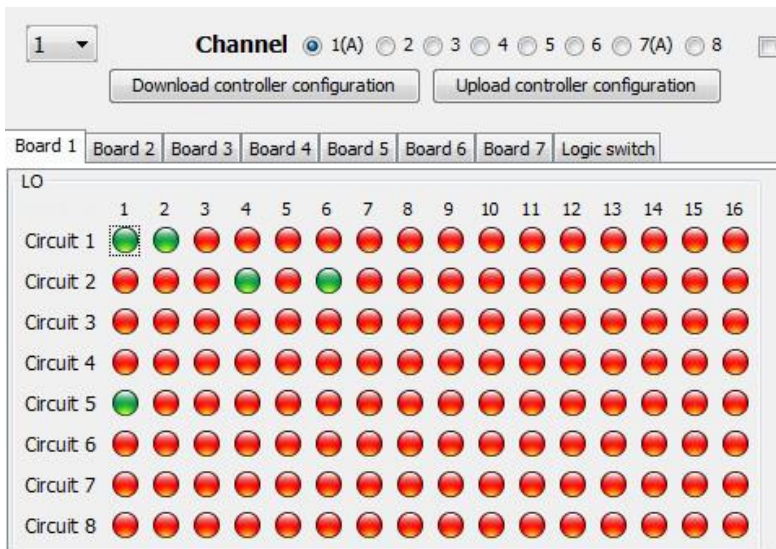

Logic group 1A: All 5 emergency luminaires are controlled by a Logic group A (channels 1 and 7)

APPENDIX 2: WIRING DIAGRAMS

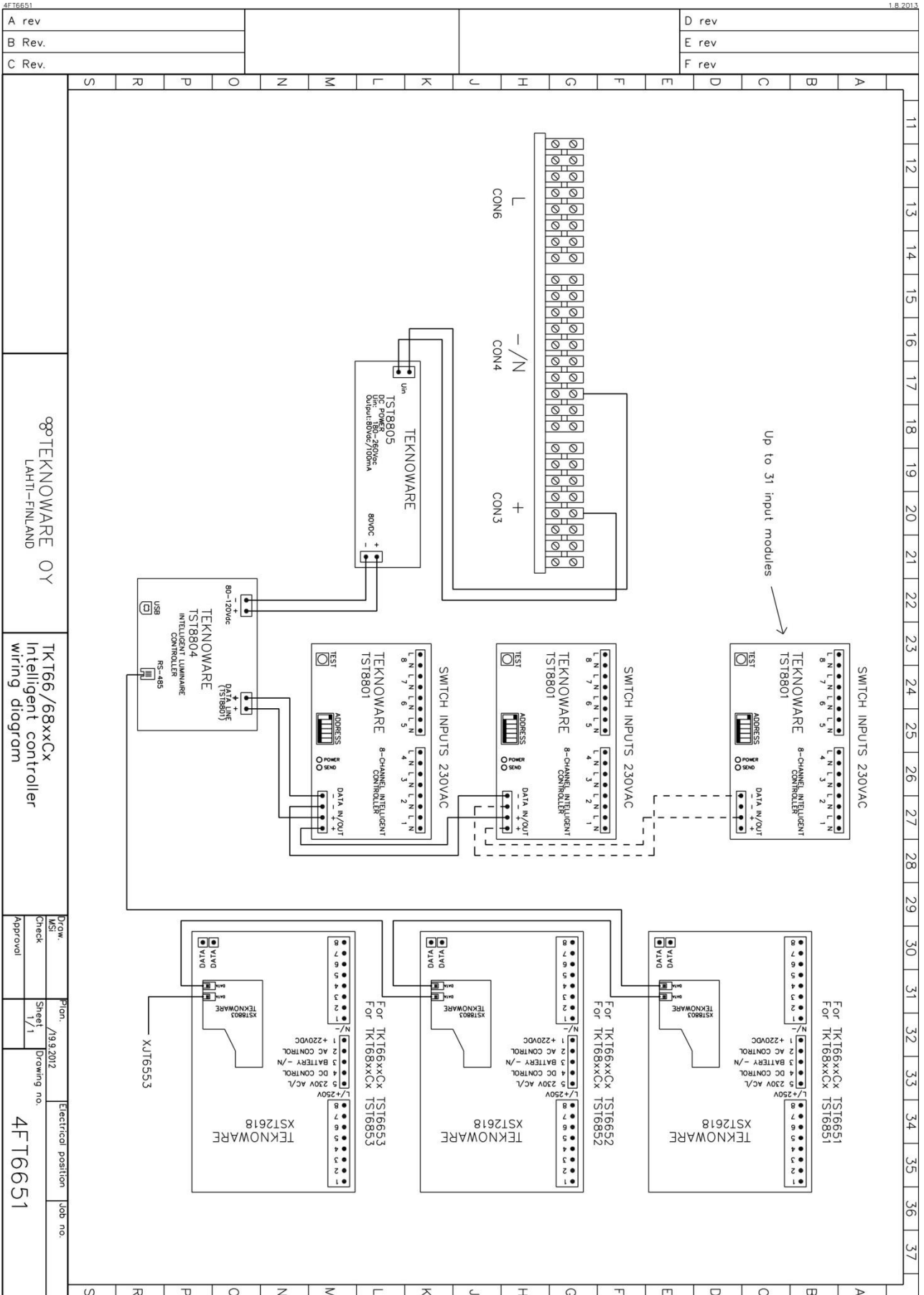

4FT6651
A rev.
B Rev.
C Rev.

1.8.2013
D rev.
E rev.
F rev.

TEKNOWARE OY
LAHTI—FINLAND

TK166/68xxxCx
Intelligent controller
wiring diagram

D'aw. /19.9.2012
Check /1/1
Approval

Plan. /19.9.2012
Sheet /1/1
Drawing no. **4FT6651**

Electrical position
Job no.

4FT6751

1.8.2013

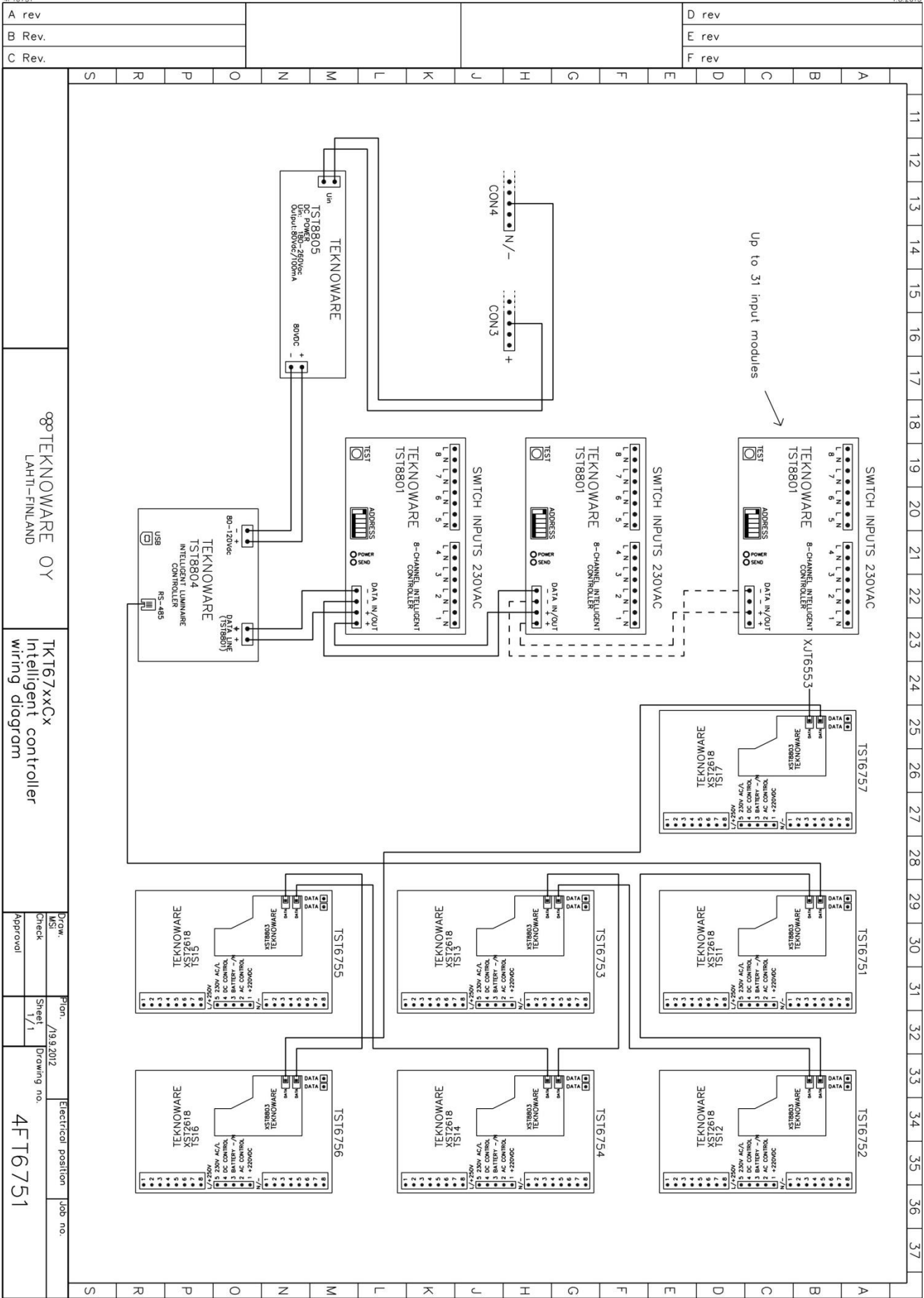

TEKNOWARE OY
LAHTI-FINLAND

TK167xxCx
Intelligent controller
wiring diagram

Proj. MS*	Plan. /19.9.2012	Electrical position	Job no.
Check	Sheet / /1	Drawing no.	4FT6751
Approval			

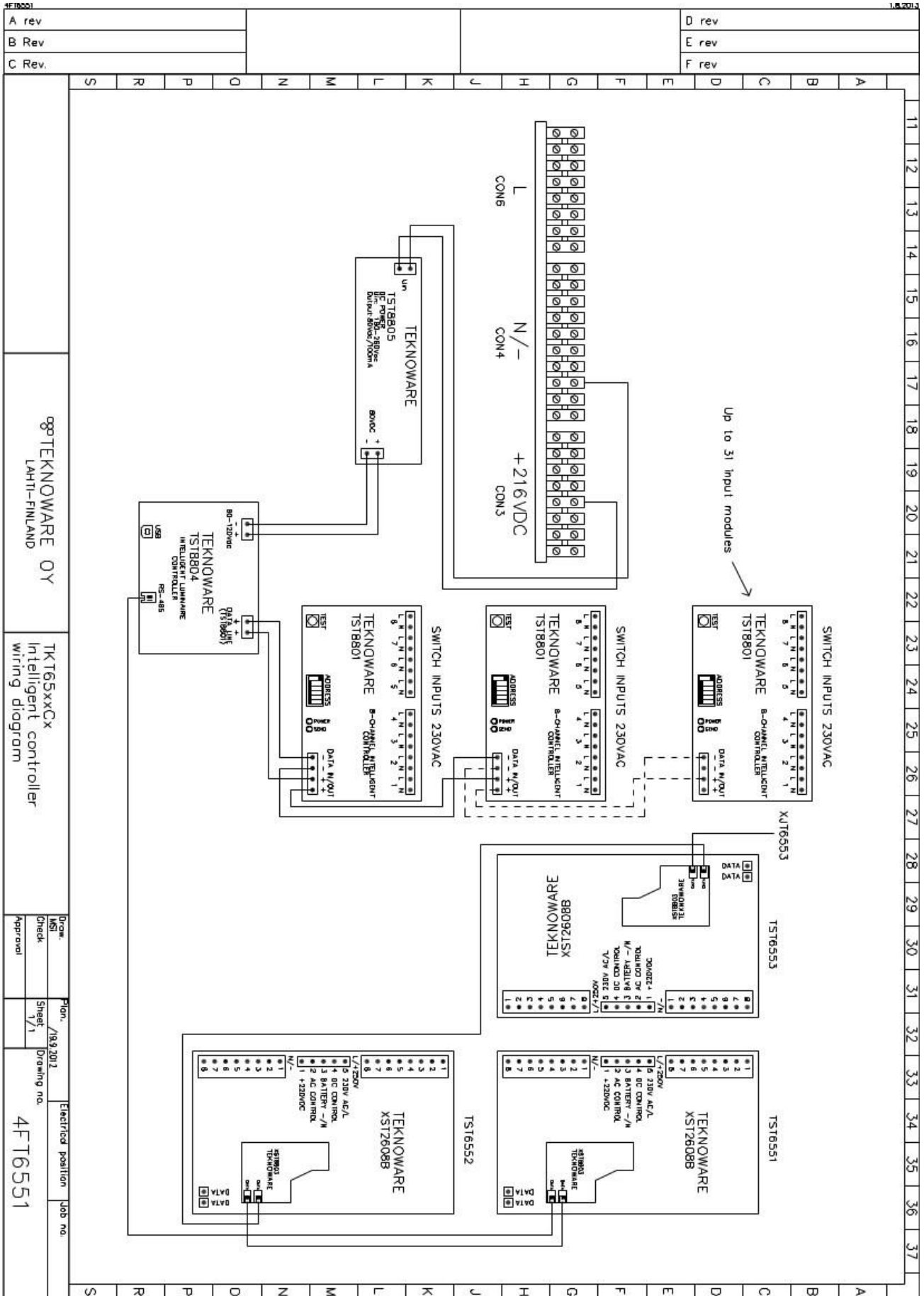

TEKNOWARE OY
LAHTI-FINLAND

TK165xxCx
Intelligent controller
wiring diagram

Doc. no.	4F16551
Check	Street /192 2013
Approval	Sheet 1/1
Electrical position	Job no.

Contact information:

Teknoware Oy, Ilmarisentie 8, FI-15200 Lahti, Tel: +358 (0)3 883 020, Fax: +358 (0)3 8830 260, Email: emexit@teknoware.fi, www.teknoware.fi



Emergency lighting unit

Email
emexit@teknoware.fi

After Sales
after sales service, technical assistance,

Email
aftersales@teknoware.fi