



Installation and User Guide



This product may only be installed or maintained by a qualified electrician.

QUICK GUIDE: FRONT PANEL INDICATOR LEDs



Central Battery Unit is ON



Mains mode



Battery mode



Batteries recharging



Error, see Chapter 8 for details about error codes



Test(s) running

Table of Contents

- 1. Product Description 5**
- 1.1 Manufacturer 5
- 1.2 Model 5
- 1.3 General Description 5
- 1.4 Storage 5
- 1.5 Technical Details 6
- 2. Planning the System 7**
- 3. Installing the System 7**
- 3.1 Connections, Parts and Layout 8
- 4. Commissioning 11**
- 5. Structure of the User Interface 11**
- 6. Main View 12**
- 7. Main Menu 12**
- 7.1 Circuit- and Luminaire Configurations 12
- 7.2 History of Tests and error log 12
- 7.3 Functions 13
- 7.4 Settings 13
- 7.5 Setting the Time 13
- 7.6 Luminaire Test Settings 13
- 7.7 Battery Settings 14

8.	Warnings and Errors	16
8.1	BATTERY ERROR	16
8.2	BATTERY OVERVOLTAGE	16
8.3	DEEP DISCHARGE	16
8.4	BATTERY UNDERVOLTAGE	16
8.5	TEMPERATURE ERROR	16
8.6	MAINS NOT PRESENT	16
8.7	MOSFET BROKEN + circuit board number	16
8.8	LUMINAIRE BROKEN	17
8.9	FUSE ERROR	17
9.	Mechanical Dimensions: TKT2404C	18
10.	Mechanical Dimensions: TKT2408C	19

1. Product Description

1.1 Manufacturer

Teknoware Oy
P.O. Box 19, FI-15101 Lahti
Ilmarisentie 8, FI-15200 Lahti
info@teknoware.com
www.teknoware.com

1.2 Model

TKT24...C

1.3 General Description

TKT24 is an addressable 24 V central battery unit (CBU) for emergency lights. The CBU is supplied with 220–240 AC mains, maintaining the battery charge and supplying the emergency light circuits with 24 VAC. If mains is disconnected, or mains supply drops below the defined limit, the CBU switches to battery mode, and supplies the emergency light circuits with 24 VDC. Battery supply is maintained until the mains is restored (with user set delay), or until the battery capacity drops to deep discharge limit.

In addition to the mentioned basic functions, the CBU has the following monitoring- and reporting functions:

- Testing of addressable luminaires, and the monitoring of their operation - indicates the address of faulty luminaire
- Tests the batteries automatically
- Tests can also be started manually
- Self-learning system: luminaires can be added or removed after commissioning
- Mode- and warning statuses can be communicated via. relay connections to building monitoring systems
- A direct data connection to Teknoware ACM system.
- All the functions of the CBU can be accessed from the LCD interface.

1.4 Storage

If the CBU and batteries are not installed directly after delivery, the following instructions must be followed:

- The CBU must be protected from humidity
- Storing temperature of the CBU and batteries: +10...+30°C.
- If the batteries are stored for an extended period of time, the batteries must be recharged every 6 months, for 12 hours at a time.

Note!

The delivery may include lead batteries, that have charge, and that may short circuit due to improper storage! Take this into account when storing the CBU.

1.5 Technical Details

Nominal Supply Voltage:	220-240 VAC, 50/60Hz, 1~
Casing / IP Class:	IP20
Output Voltage:	Main supply: 24 VAC, Battery supply: 24 VDC
Battery Voltage:	24 VDC
Battery Recharge Time:	12 h (80 %)
Batteries:	TKT2404C: 2 x 17 Ah TKT2408C: 2 x 38 Ah
Max Input Power:	TKT2404C: 400 VA TKT2408C: 700 VA
Ambient temperature:	+10...+30°C
Max. total load,battery operation 1 h	TKT2404C: 210 W TKT2408C: 400 W
Max. total load,battery operation 3 h	TKT2404C: 90 W TKT2408C: 190 W
CBU Input Fuse:	1~ Circuit breaker, 16 A, C-curve
Output Circuit Fuses:	5 x 20 mm:n glass tube fuse 4 AT
Battery Fuse:	Circuit breaker32 A/250 VDC
Output connector:	Max. wire 4 mm ²
Mass (without batteries):	TKT2404C: 11,1 kg TKT2408C: 16,0 kg

Voltage limits

- When mains drops below 165 VAC, the CBU supplies voltage for the emergency lighting from the batteries
- When mains is disconnected, the CBU supplies voltage for the emergency lighting from the batteries.
- If the battery voltage rises above 28,5 V, the CBU gives a Battery Overvoltage warning
- If the battery voltage drops below 21,6 V:n, the CBU gives a Battery Undervoltage warning.
- During battery mode, if the battery voltage drops below 19,6 V:n, the CBU goes into deep discharge mode.

2. Planning the System

In TKT24C system the monitoring data between the CBU and the luminaires is transferred via the circuit cables. There is no need for separate data cabling, and the supply cables can be drawn as any emergency lighting cabling would be. The following, how ever, must be taken into account:

- All luminaires must be addressable Teknoware 24 V luminaires. The product code must end with ..41..K, for example TWT9041WK. These type of luminaires contain the necessary electronics for the communication between the CBU and the luminaires.

Each of the luminaires within a circuit must have an individual address. (1..32). Addresses can be chosen freely, as long as there is no overlapping addresses within a circuit. The addresses are marked to the included label according to electrical planning (circuit nr. / luminaire nr.). Additional information about setting the address can be found from the documents delivered with the luminaires.

3. Installing the System and Choosing Language

Make sure to read Chapter 3.1. "Connections, Parts and Layout" before installing the system.

1. Open the case by unfastening the two screws.
2. Attach the CBU firmly to a wall. Use all four wall mounting holes (see image in Chapter 3.1 to locate them), and take notice of the mass of the CBU and batteries.
3. Make sure that the input- and the battery fuses are in position 0 before connections.
4. Connect the circuits.
5. If applicable, connect the ACM data cable, relay-guided devices, and remote control.
6. Connect mains cable.
7. Lift the batteries to the battery shelf.
8. Place the temperature sensor between the batteries.
9. Connect the batteries in series (check the polarity and insulation distances). Start from the furthest battery (looking from the battery fuse), and connect the battery connected to the battery fuse last.
10. Check the batteries and connections for short circuits.
11. Switch the battery fuse to position 1
12. To continue installation without changin the default language (English), simply switch the input fuse to position 1. If you wish to change the user interface language, press the selection button (the black button below the LCD screen), hold the button down, switch the input fuse to position 1, and wait for the language selection to appear on the screen. Select the language, and press the button again.

- 13. Fasten the case with the two screws
- 14. The CBU is ready for commissioning

3.1 Connections, Parts and Layout

3.1.1 Relay connections and remote control

WORK-relay: relay is in normal closed position, when the CBU is operating.

BATT-relay: relay is in normal closed position, when the CBU is in battery mode.

ERROR-relay: relay is in normal closed position, when there is an internal fault in the CBU (luminaire error does not change the relay position)

Remote control: When a relay connected to this is in normal open position, the CBU goes into battery mode.

3.1.2 Connection to Teknoware Advanced Monitoring (ACM)

If you are using the Teknoware Advanced Central Monitoring (ACM) -software, you can connect the TKT24 CBU directly to the modem. Give the CBU an individual local address during commissioning (see details from Chapter 7.7.6 Local Address). For more information about installing ACM, see document "VOT132 - ACM for TKT24 USER GUIDE"

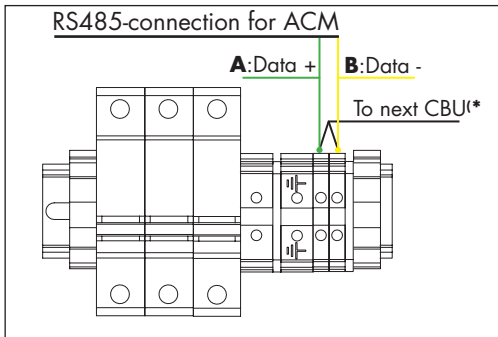

*) Multi-Pair RS-485 22 – 24 AWG Cable, max 1200m

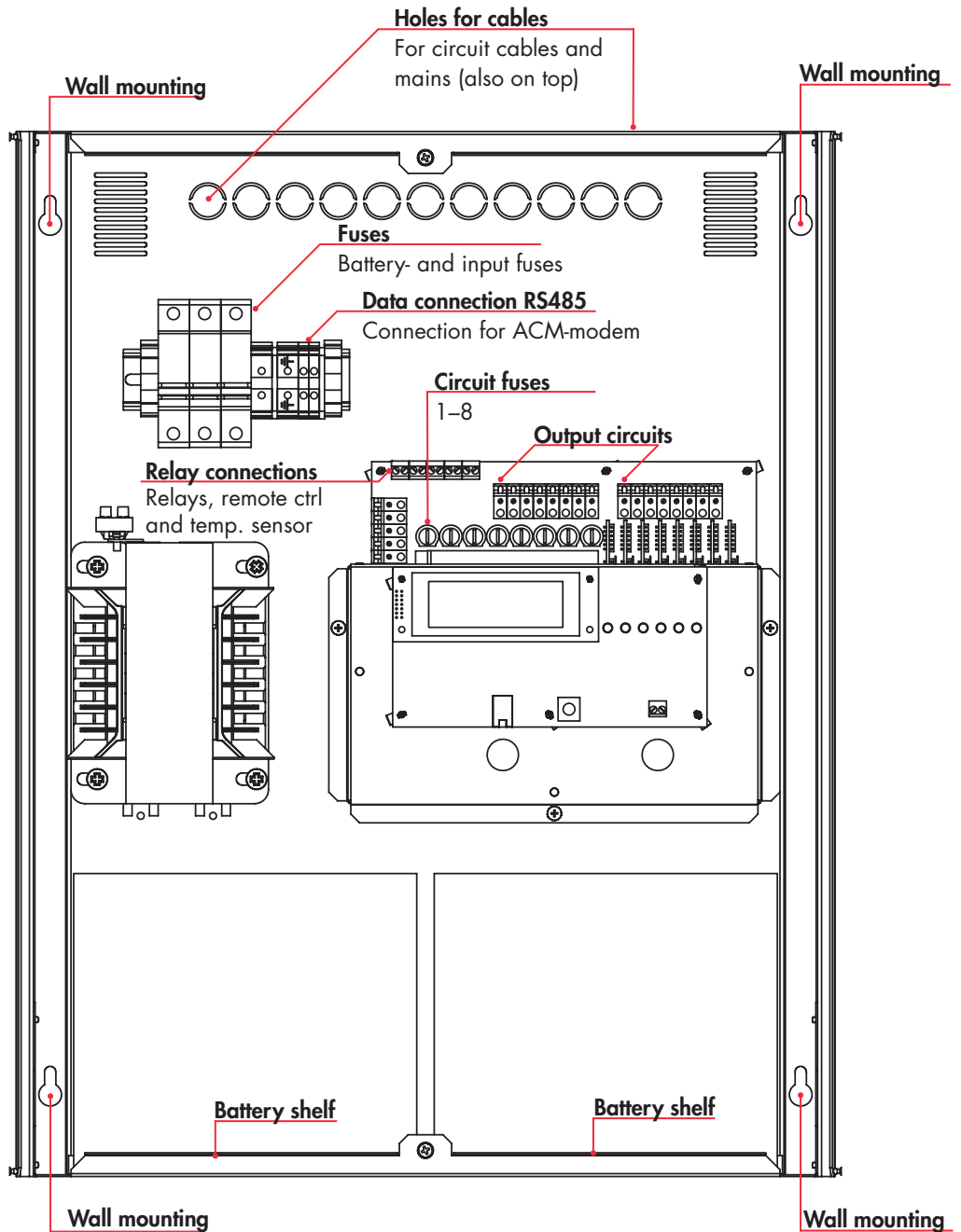

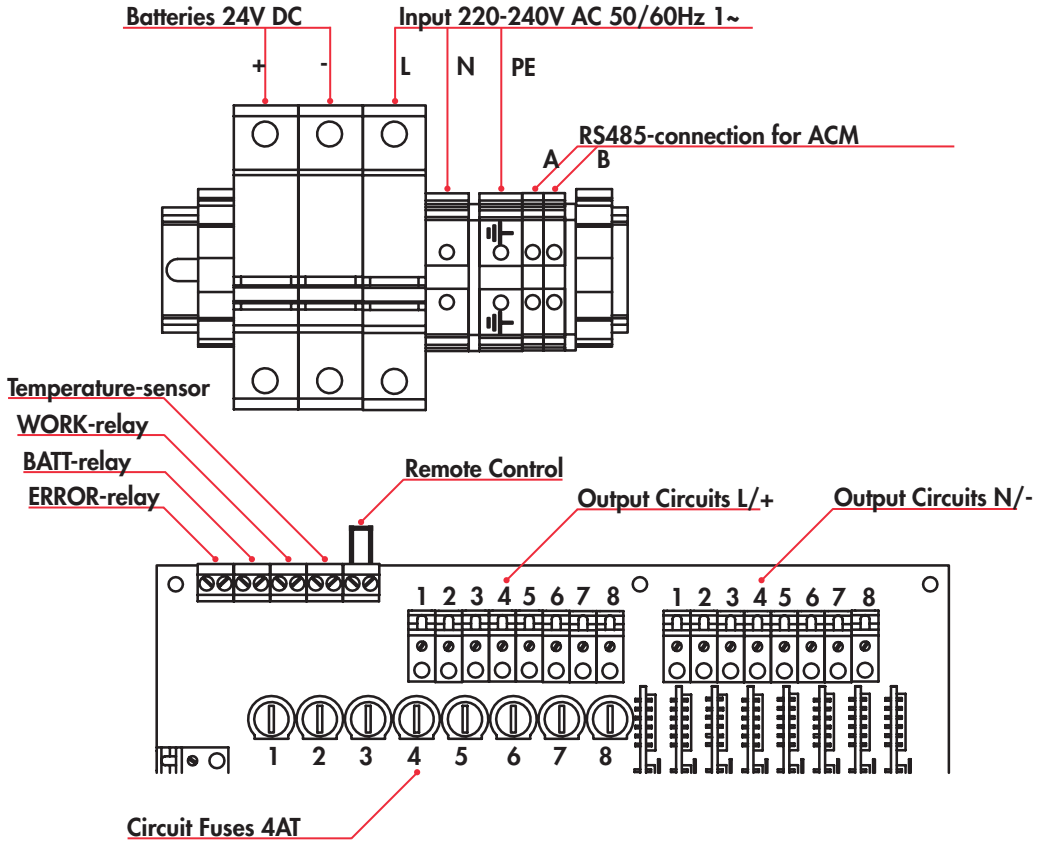

4. Commissioning

Using the selection button: Choose an action by rotating the selection button. A short press chooses the selected action. A long press (2 sec) returns the system to previous view, and saves made changes.

After the CBU is installed, make sure all the luminaires are functioning correctly. Then, set up the system by making the following settings:

1. Set the time - see chapter 7.5
2. Set the battery operating time - see chapter 7.1.1
3. Set the schedule for battery test - see chapter 7.7.2
4. Set the schedule for luminaire tests - see chapter 7.6.1
5. Set the test interval for luminaire tests - see chapter 7.6.2
6. Optional: set a delay for switching back from battery mode - see chapter 7.7.3
7. Optional: set a password - see chapter 7.7.5
8. Optional: set a local address for the CBU for ACM - see chapter 7.7.6.
9. Get luminaire configuration – see chapter 7.3

Changing the luminaire configuration

If the luminaire configuration changes after the initial commissioning (luminaires are added or removed), the luminaire configuration must be ran again. The system compares the results of luminaire tests to the existing configuration, so for example changes in the amount of luminaires in the system may cause errors. See chapter 7.3.

5. Structure of the User Interface

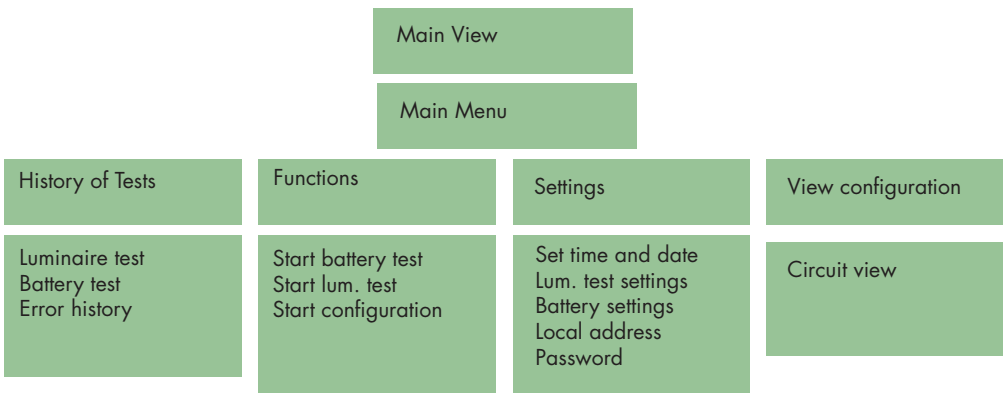

6. Main View

- Visible without password.
- **Not configured:** Luminaire configuration has not been made yet
- **System OK:** Luminaire configuration has been made and the system is functioning normally
- If the system has errors, the warning is displayed in this view. The error messages are listed in Chapter 8.
- Short press of selection button opens Main Menu

```
01.01.2018 08:00
SYSTEM OK
VOLTAGE 23.3V
CURRENT 04.2A CHARGE
```

7. Main Menu

- **View configuration:** View circuit- and luminaire configurations
- **History of tests:** View test history
- **Functions:** Start luminaire test, start battery test, start configuration

```
>VIEW CONFIGURATION
HISTORY OF TESTS
FUNCTIONS
SETTINGS
```

7.1 Circuit- and Luminaire Configurations

View configuration

- **Empty:** There is no luminaires in the circuit
- **OK:** Circuit contains luminaires - all functioning normally
- **Error:** Circuit contains luminaires - one or several luminaires have reported and error
- View luminaire configurations by selecting a circuit with the selection button

```
SELECT CIRCUIT
>06-OK 0.1 A
07-EMPTY 0.0 A
08-ERROR 0.1 A
```

View configuration > a circuit is selected

- A detailed view of the selected circuit
 - * = emergency luminaire
 - > = exit luminaire
 - # = faulty luminaire
 - . = empty

```
CIRCUIT 1 0.3 A
LO-■...*...→.....
HI-....#.....
```

7.2 History of Tests and error log

History of tests

- **Luminaire test**
- **Battery test**
- **Error history**

```
SELECT TESTS LOG
>LUMINAIRE TEST
BATTERY TEST
ERROR HISTORY
```

7.3 Functions

```
SELECT FUNCTION
>START LUM. TEST
START BATTERY TEST
START CONFIGURATION
```

Functions

- **Start lum. test:** Starts luminaire test. When a test is running, **Stop lum. test** stops the test.
- **Start battery test:** Starts a battery test. When a test is running, **Stop battery test** stops the test.
- **Start configuration:** Starts the luminaire search. When the search is running, **Stop configuration** stops the search.
- **Print report:** Only for maintenance use.

```
SELECT FUNCTION
>START CONFIGURATION
PRINT REPORT
```

7.4 Settings

```
SETTINGS
>SET TIME AND DATE
LUM. TEST SETTINGS
BATTERY SETTINGS
```

Settings

- **Set time and date**
- **Lum. test settings**
- **Battery settings**
- **Local address:** Set a local address for the CBU (for ACM)
Setup password: Set a password to protect the system from unauthorized access.

```
SETTINGS
>BATTERY SETTINGS
LOCAL ADDRESS
SETUP PASSWORD
```

7.5 Setting the Time

```
SET TIME AND DATE
01.01.2018 08:00
```

Settings > Set time and date

- Set the time and date for the system: clockwise rotation - increase, counterclockwise - decrease, short press - next position, long press - exit and save.

7.6 Luminaire Test Settings

```
LUM. TEST SETTINGS
>SET TIME
SET INTERVAL
AUTO START ON
```

Settings > Lum. test settings

- **Set time:** Set the test time
- **Set interval:** Set the test interval (i.e. how often the tests are run)
- **Auto start ON / OFF:** Set the automatic testing ON or OFF.

Note! If you are planning to use the scheduled testing option in the ACM software, it is recommended not to use the automatic testing from the CBU.

7.6.1 Luminaire Test Time

LUM. TEST START TIME

09:00
^^

Settings > Lum. test settings > Set time

- Set the time you want the luminaire test to start at by rotating the selection button
- Short press of the button moves the selection to minutes
- Long press of the button saves the time and exits the menu.

Note! Please note that the luminaires may blink during the tests. The test time should be set in a way, that the building is empty, for example outside business hours.

7.6.2 Time Interval for Luminaire Tests

LUM. TEST INTERVAL

1 DAY(S)

Settings > Lum. test settings > Set interval

- Set the time interval for luminaire tests. **1 Day(s)** = tests are run every day. **7 Day(s)** = tests are run every week.

7.7 Battery Settings

BATTERY SETTINGS
>SET SWITCH DELAY
BATTERY TEST DATE

Settings > Battery settings

- **Set operation time:** Set the intended operation time for batteries (for testing purpose)
- **Battery test mode:** Battery test settings
- **Set switch delay:** Set a delay for battery mode switch
- **Battery test date**

7.7.1 Battery Operating Time

BATTERY OPERATION
TIME
090 MINUTES

Settings > Battery settings > Set operation time

- You may choose an operation time for the batteries between 60–240 minutes. This value is used for testing the battery.

7.7.2 Battery Test Mode (test time)

Settings > Battery Settings > Battery test mode

BATTERY TEST MODE
>FULL TIME
2/3 OPERATION TIME
TO UNDERVOLTAGE

- **Full time:** Tests the battery for full user set operation time .
- **2/3 Operation time:** Tests the battery for 2/3 of user set operation time, and compares remaining charge to the battery capacity
- **To undervoltage:** Tests the battery until undervoltage

Note! The batteries must be completely charged before running tests. Use "Full time" -test and "To undervoltage" -test only manually, and only when the building is not occupied! Don't use these options for automatic battery tests.

7.7.3 Battery Mode Switch Delay

BATTERY SWITCH DELAY
00 MINUTES

Settings > Battery settings > Set switch delay

- A delay for returning to mains mode from battery mode. This is meant for avoiding the blinking of emergency lights in a situation where mains power is restored and lost several times in a short period of time (as is often the case during a power failure). Set the time, and press the selection button long to save and exit.

7.7.4 Battery Test Date

BATTERY TEST
AUTOMATIC START
ON 01.01.2019
^^

Settings > Battery test date

- Set a date for battery test. The test starts on said date, 00:00.

Note! Take into account local laws and legislations concerning battery tests. Battery tests may not be allowed to be ran if there is people in the buiding. It may be a good idea, for example, to time the battery test to a national holiday.

7.7.5 Password Protection

SETUP PASSWORD

■***

Settings > Setup password

- Set a four-digit password with the selection button. Save the password and exit by pressing the selection button long. If you want to disable the password, set 0000 as the password.
- When the system is password protected, only the main view is visible without the password. This means, that checking CBU status and errors can be done without logging in.
- If you forget your password, contact Teknoware Technical Service.

7.7.6 Local Address

LOCAL ADDRESS 1

Settings > Local address

- This is the local address of the CBU, for ACM use.
- Set an address (1-150) with the selection button. If there are more than one CBU in the system, make sure you write down the address and the physical location of the CBU: this will be important when setting the CBU location to the ACM map view. Please note that the TKT24 ACM system supports up to 30 CBUs.

8. Warnings and Errors



Installing, commissioning and maintaining the system may only be done by a qualified electrician.

8.1 BATTERY ERROR

Error generates if the batteries are not connected, or the batteries are faulty. Check the batteries. If the battery is OK, check the fuse, and replace if necessary.

8.2 BATTERY OVERVOLTAGE

Battery voltage has exceeded 28 volts. Using the battery may be dangerous. Stop battery recharging by disconnecting the CBU from mains, and check the system for malfunctions.

8.3 DEEP DISCHARGE

Battery voltage has dropped below 19,6 volts. Error will be removed, after the battery voltage exceeds 19,6 volts, and the user acknowledges the error message by pressing the selection button. During the error, the CBU will be in power save mode.

8.4 BATTERY UNDERVOLTAGE

Battery voltage has dropped below 21,6 volts. After the batteries have been recharged, the error message disappears automatically.

8.5 TEMPERATURE ERROR

Battery temperature is below +10°C or over +50°C. The error might also occur, if the temperature sensor is faulty, or connected wrong.

8.6 MAINS NOT PRESENT

Mains is not present. If the CBU is connected to mains, check the fuses.

8.7 MOSFET BROKEN + circuit board number

Circuit board transistor is faulty. Change the circuit board (available as spare part, contact Teknoware Technical Service).

8.8 LUMINAIRE BROKEN

One or more luminaire(s) is faulty. Check the circuit and address of the luminaire, and replace or fix the luminaire.

8.9 FUSE ERROR

There are luminaires defined for a circuit, but there is no electrical load in the circuit. Check the circuit fuse. If there is only one luminaire in the circuit, this might also indicate that said luminaire is faulty, or connected incorrectly.

9. Mechanical Dimensions: TKT2404C

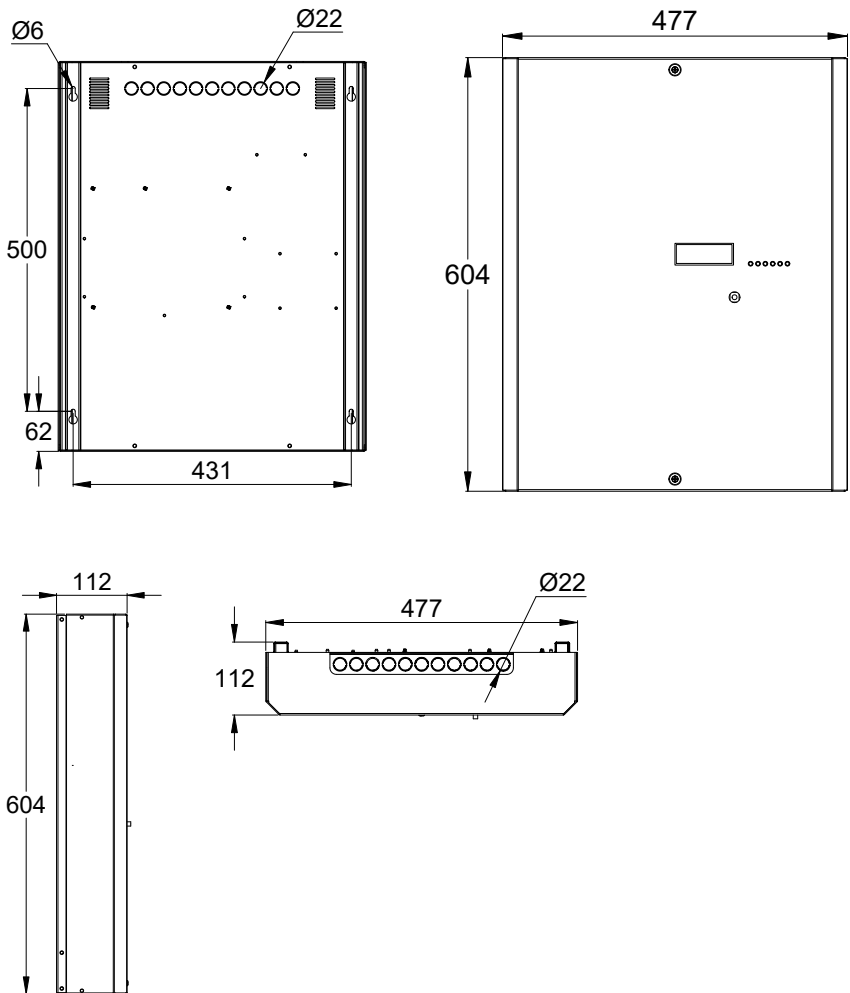

10. Mechanical Dimensions: TKT2408C

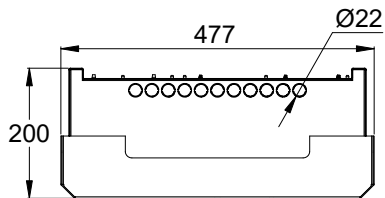
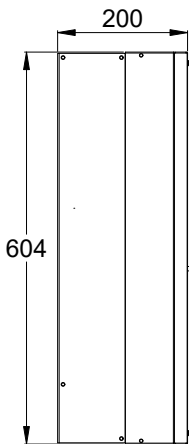
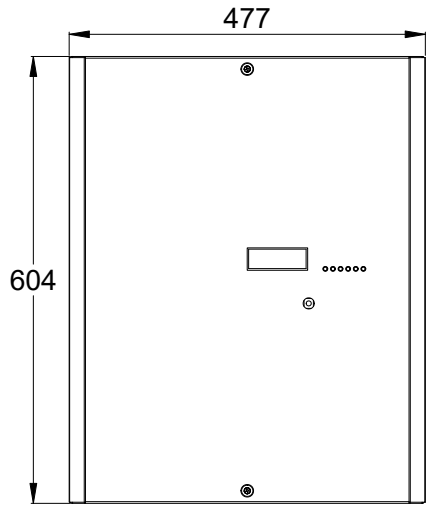
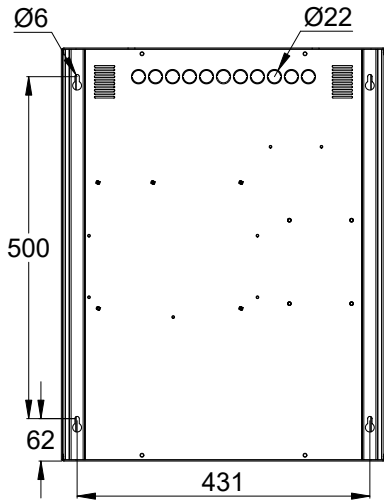

TKT24 Central Battery Unit, User's Guide
VOT112E, R1.2 – 21.1.2026



P.O. Box 19, FI-15101 Lahti
Ilmarisentie 8, FI-15200 Lahti

Tel: +358 3 883 020
Fax: +358 3 883 0240
emexit@teknoware.com

teknoware.com